

**HURRICANE VENTILATOR**

DATE: 29 January 1999

REVISED: 7 September 2001

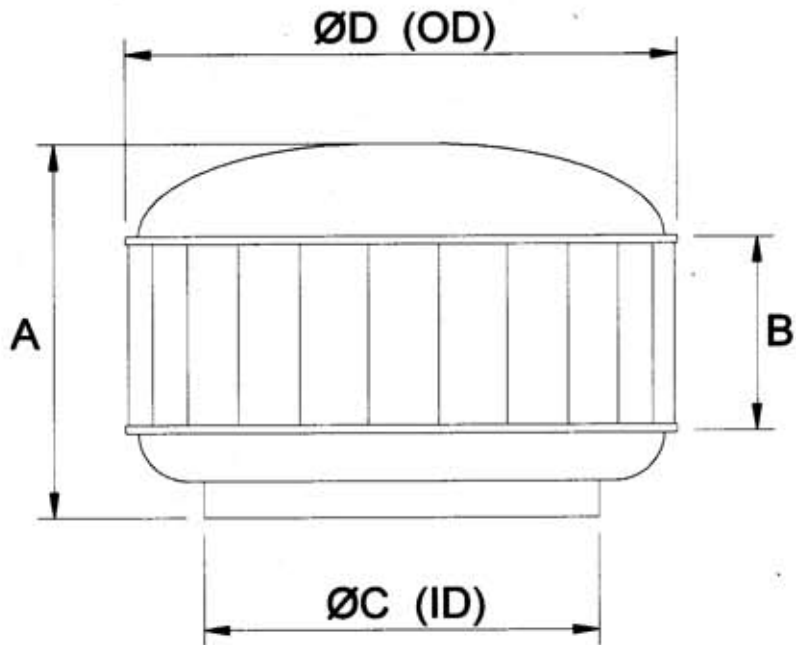

**DIMENSIONS:**

MODEL	A (mm)	B (mm)	ØC (mm)	ØD (mm)	Throat Area (m <sup>2</sup> )	Weight (kg)
H900	643	400	897	1096	0.6319	18.1

Tolerances: Size +/- 2mm  
Weight +/- 0.1kg

**SPECIFICATIONS:**

**MATERIAL:**

Turbine & throat: Aluminium 5005 H34  
 Shaft: Aluminium 2011 T3  
 Dome & skirt: Aluminium 1200 H0  
 Brackets: Aluminium 6060 T591  
 Spider (H600-H900 only): Zinc passivate plated mild steel  
 Shaft (H900 only): Stainless Steel

**ROTATION BEARINGS:**

Main bearing: Double row ball bearing - BWF30-119Z  
 Spider bearing (H600-H900 only): Single row ball bearing - UB204-12S

**WIND SPEED RATING:**

205.2km/h (57m/s) – Performance level 1  
 (As per AS 4740:2000 Natural ventilators-Classification and performance)